

Performance Analysis of Photovoltaic Array with H5 inverter under Partial Shading Conditions

V. Thiyagarajan¹ and P. Somasundaram²

¹Assistant Professor, Department of EEE,
SSN College of Engineering,
Kalavakkam, Tamilnadu, India

²Associate Professor, Department of EEE,
College of Engineering Guindy, Anna University,
Chennai, Tamilnadu, India

Copyright © 2016 ISSR Journals. This is an open access article distributed under the *Creative Commons Attribution License*, which permits unrestricted use, distribution, and reproduction in any medium, provided the original work is properly cited.

ABSTRACT: In recent years, the effect of partial shading on the energy yield of photovoltaic array has been widely analysed. Partial shading conditions caused due to moving clouds and shadows of nearby objects on a photovoltaic array can have a significant effect on its energy yield. The power output of the photovoltaic array under partial shading depends on the PV array configuration, shading pattern and the physical location of shaded modules in the array. The amount of power generated by the photovoltaic array also changes continuously with the changes in weather conditions. Therefore it is very important to understand the characteristics of photovoltaic array under non uniform irradiation condition in order to achieve higher efficiency under all conditions. The main objective of this paper is to analyse the performance of different configurations of photovoltaic array with H5 inverter under partial shading conditions. The simulation was done using MATLAB/SIMULINK environment.

KEYWORDS: Photovoltaic array, Series-Parallel, Total Cross Tied, Bridge link, partial shading, H5 Inverter.

1 INTRODUCTION

To guarantee sustainability of future demand, there is a need to develop and implement the renewable energy technologies. The Photovoltaic (PV) energy is one of the most valuable and widely used renewable energy sources due to its abundance, accessibility and reliability. The PV system can be operated either in island or grid connected mode. The grid connected mode of PV system injects the power into the electrical grid. In order to achieve this objective, the PV system is usually set by using three stages: the PV array, the power inverter and the filter with galvanic isolation [1]. In this case, transformer is integrated into the grid-connected operation of PV system for the galvanic isolation, leakage current suppression and dc injection which improves the system safety and reducing failure risks. However, it will increase the cost and reduces the system efficiency. On the other hand, the transformerless inverter for PV applications reduces the cost, size, weight of the conversion stage and increases the system overall efficiency [2]. The photovoltaic inverters have relatively low impact in the initial investment cost, responding for approximately 10% of the total in comparison with 70% for the PV modules and 20% for the installation and planning. The low power PV applications have limited range of input voltage. In order to achieve high dc input voltage, a large number of PV modules are connected in series. However, this configuration subject to partial shading which affects the power output level of the PV modules.

In this paper, the performance of different topologies of photovoltaic array with H5 inverter under partial shading conditions is analysed using MATLAB/SIMULINK. The power output for partial shaded PV array and efficiency of H5 inverter are compared for different configuration of PV array.

2 MODEL OF PV ARRAY

A photovoltaic cell is basically a P-N semiconductor junction diode which converts solar energy into electrical energy. A practical solar cell is modeled as a current source in parallel with a diode, a series resistor (R_s) and a shunt resistor (R_p) as shown in Fig. 1 [3],[4]. The value of series resistor is small when compared with shunt resistor.

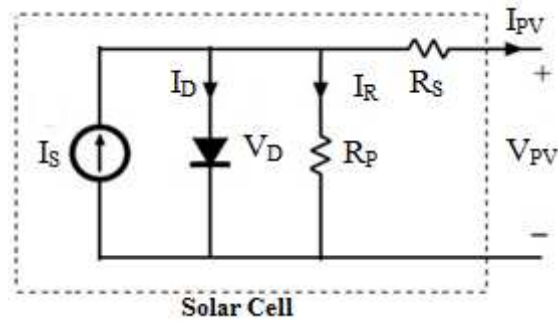

Fig. 1. Equivalent circuit of a solar cell

By Kirchhoff's Current Law (KCL), we get

$$I_S = I_D + I_R + I_{PV}$$

$$\text{or } I_S = I_D + \frac{V_D}{R_p} + I_{PV}$$

Where, I_S is the isolation current, I_{PV} is the solar cell current, I_D is the current in the bypass diode and V_{PV} is the voltage across solar cell.

The characteristics equation of bypass diode across the PV module is given by the equation,

$$I_D = I_0(e^{V_D/V_T} - 1)$$

Where, I_0 is the reverse saturation current and V_T is the thermal voltage.

Since, the photovoltaic array is made up of several solar cells connected in series, the current in each of the series solar array is given by the equation,

$$I_{PV} = I_S - I_0 \left(e^{V_D/N_s V_T} - 1 \right) - \frac{V_{PV} + R_S I_{PV}}{R_p}$$

Where, N_s is the number of solar cells in series. The parameters of solar cell are given in Table 1.

Table 1. Solar Cell Parameters

Parameters	Values
Short Circuit Current, I_{SC}	8.28
Open Circuit Voltage, V_{OC}	37.8
Current at rated power, I_{MAX}	8.05
Voltage at maximum power, V_{MAX}	31.1

The voltage-current (VI) and power-voltage (PV) characteristics of the typical single diode solar cell for different isolation is shown in Fig.2. Due to the variation in the solar irradiation, the photovoltaic array exhibits non-linear characteristics i.e., Power-Voltage (PV) and Voltage-Current (VI) characteristics.

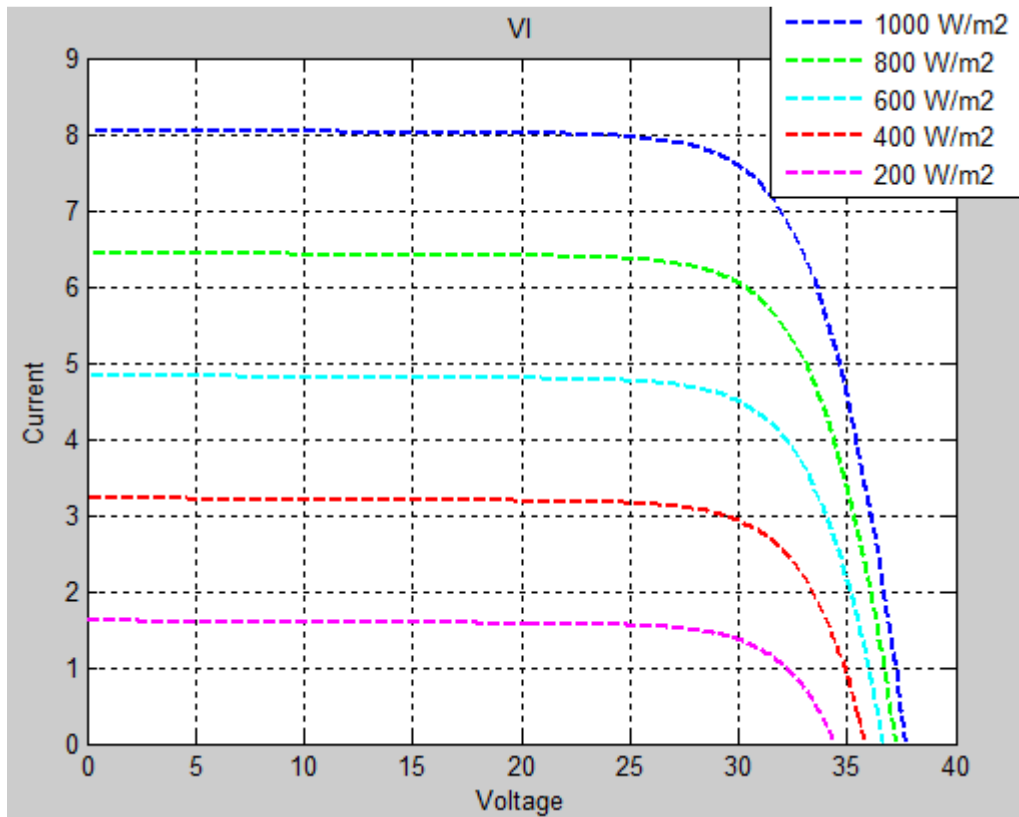

(a)

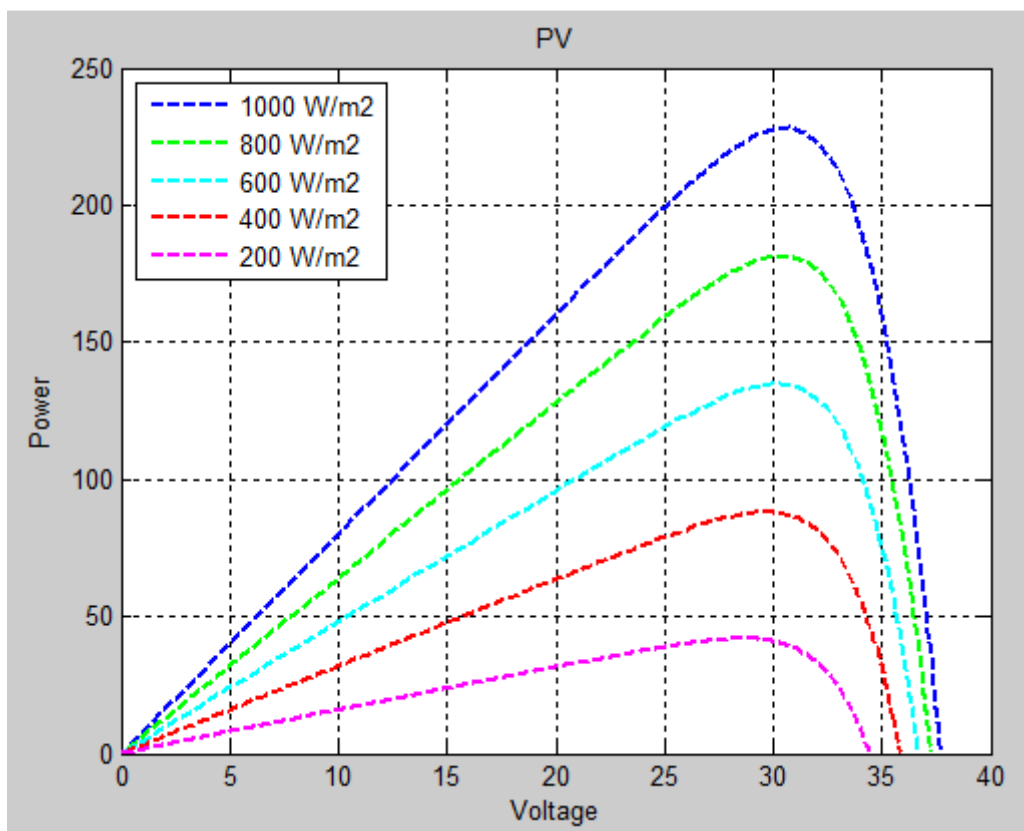

(b)

Fig. 2. Solar cell (a) VI characteristics (b) PV characteristics

3 PARTIAL SHADING OF PV ARRAY

Partial shading is the main cause for reducing energy yield of grid-connected photovoltaic systems, especially it has great impact on larger arrays. The photovoltaic array consists of a number of photovoltaic modules connected in series, parallel or combination of both. The different configurations of photovoltaic array are series, parallel, Series-Parallel (SP), Total Cross Tied (TCT) and Bridge Link (BL) configurations. The different configurations of photovoltaic array are shown in Fig. 3.

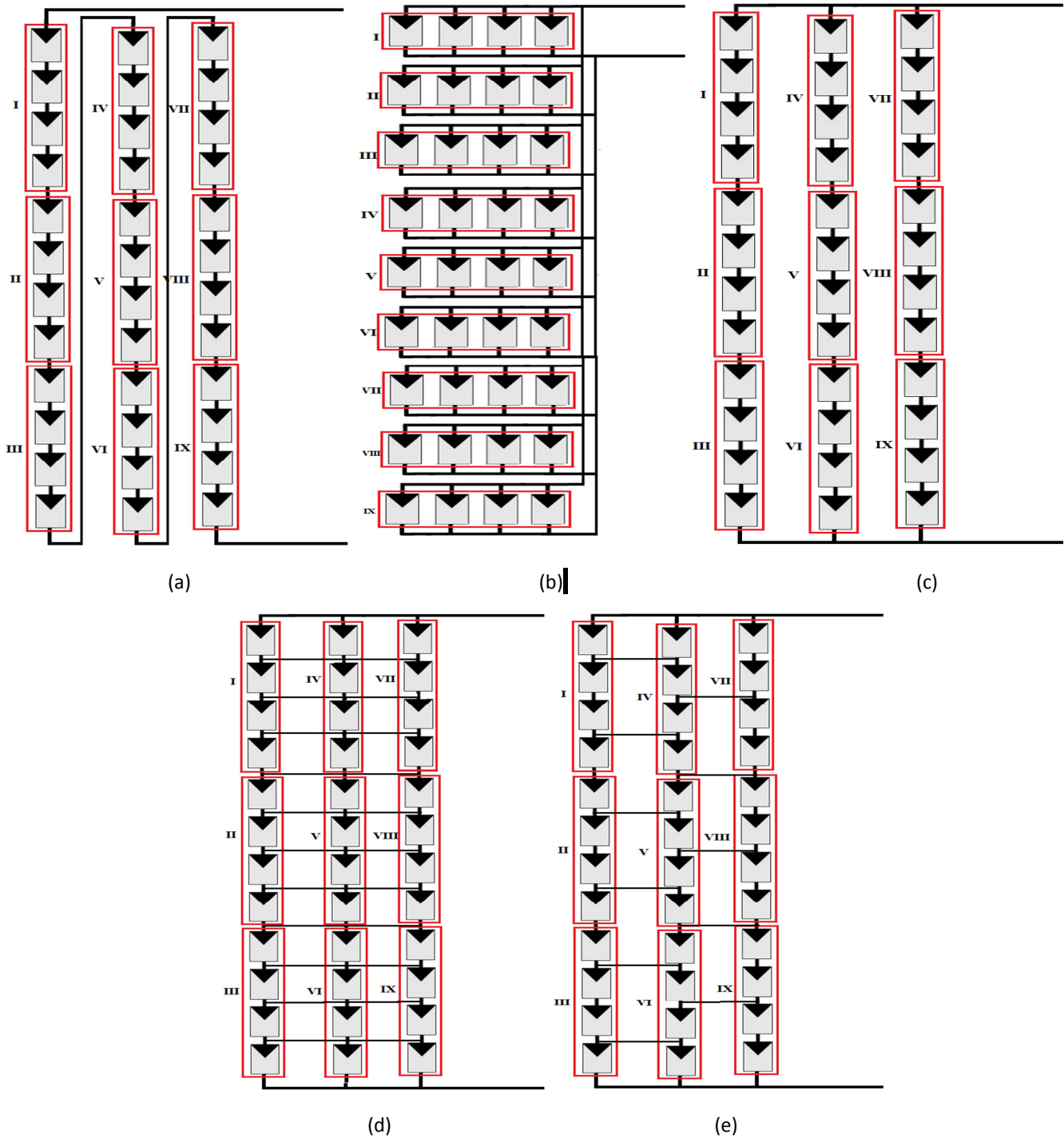

Fig. 3. Different configurations of photovoltaic array (a) Series (b) Parallel (c) Series-Parallel (SP) (d) Total Cross Tied (TCT) and (e) Bridge link (BL)

The proposed PV array includes 36 PV modules which are divided into nine groups each consisting of 4 PV modules. In series connection, all 36 PV modules are arranged in series as shown in Fig. (a). All 36 PV modules are arranged in parallel for parallel configuration as shown in Fig. (b). The entire 36 PV modules are arranged in a 12x3 array configuration for series-parallel, total cross tied and bridge link as shown in Fig. (c), (d) and (e) respectively. The irradiance level of various groups of PV modules for different patterns used in this paper are given in Table 2.

Table 2. Irradiance Level

Group	Irradiance (W/m ²)		
	Pattern - 1	Pattern - 2	Pattern - 3
I	1000	1000	1000
II	1000	1000	800
III	1000	1000	600
IV	1000	1000	1000
V	1000	800	800
VI	1000	1000	600
VII	1000	1000	1000
VIII	1000	600	800
IX	1000	600	600

The voltage-current (VI) and power-voltage (PV) characteristics of series-parallel configuration of the photovoltaic array for different shading pattern is shown in Fig. 4.

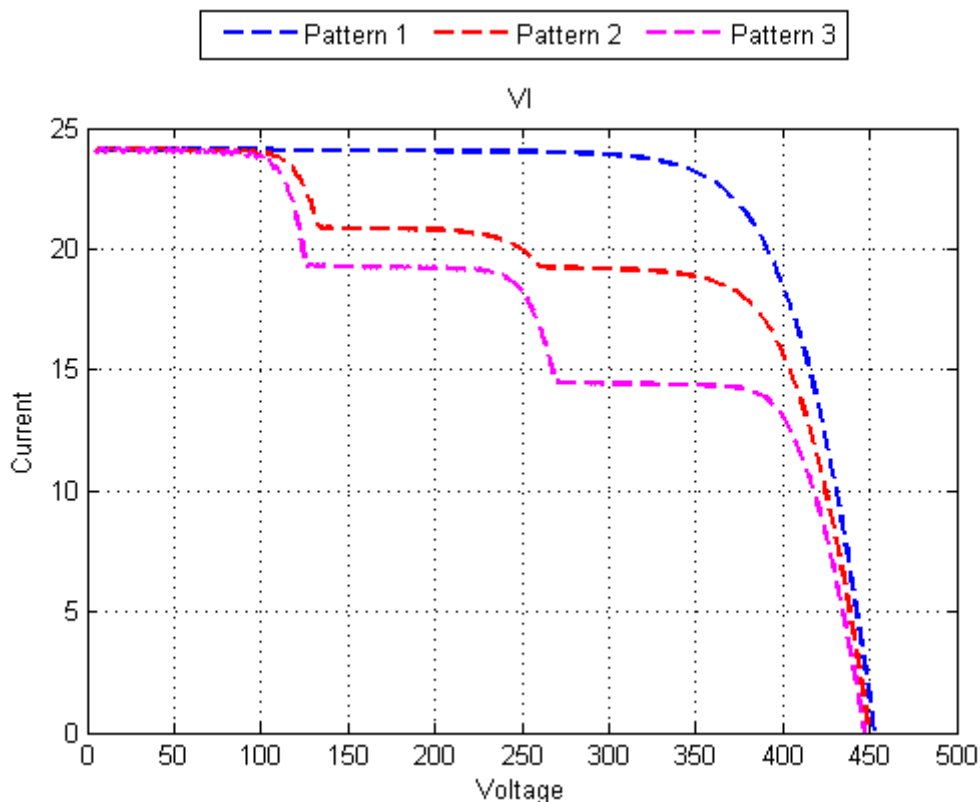

(a)

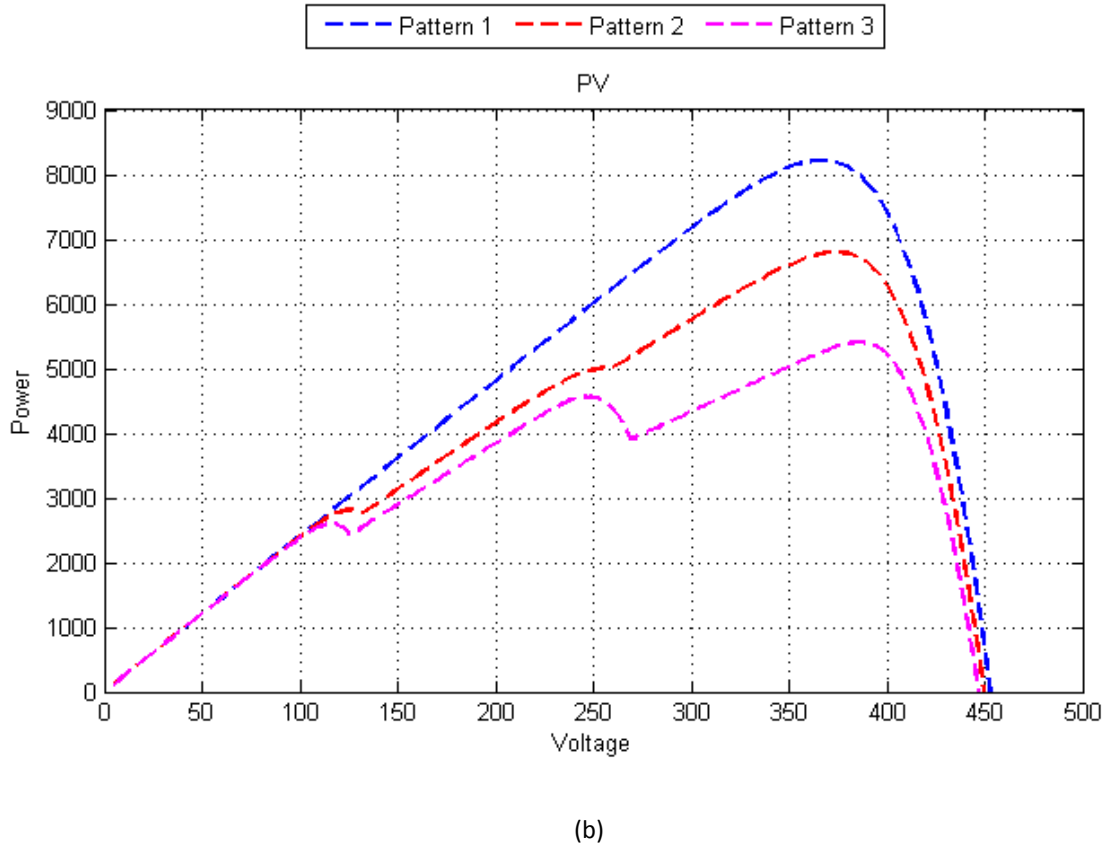

Fig. 4. Photovoltaic array (a) VI characteristics (b) PV characteristics

4 MODEL OF H5 INVERTER

Inverters are the most important power electronics equipment in the operation of grid tied PV systems. The major role of the inverter is to convert DC power into AC power. The H5 topology is shown in Fig. 5.[6] It is a classical H bridge inverter with a unipolar type of switching which employs an additional switch on the dc side of inverter. It has simple structure, less weight and provides higher efficiency. It allows disconnection of the PV array from the grid when output voltage of the inverter is at zero voltage level and provides a disconnection from the DC side. Thus the leakage current path is cut off which ensure zero leakage ground current.

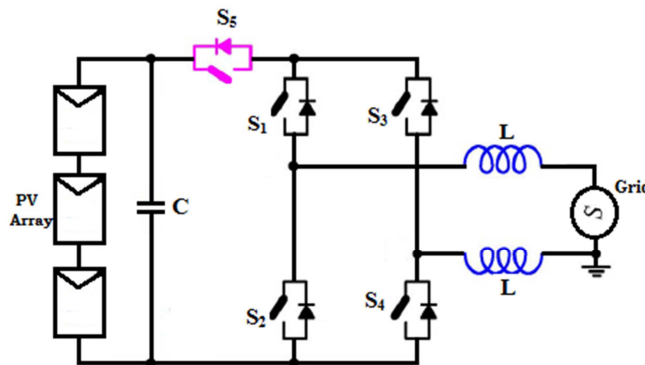

Fig. 5. H5 topology

The upper pair of switches S_1 and S_3 are operates at low frequency, usually at grid frequency, while the lower pair of switches S_2 and S_4 operates at high frequency, usually at switching frequency. During the positive half cycle, S_1 is ON, while S_4 and S_5 are switched simultaneously at the switching frequency and the current will flow through $S_5 - S_1$ returning through S_4 . During the positive zero voltage, S_4 and S_5 are turned OFF and the freewheeling current flows through S_1 and diode of S_3 . In

negative half cycle, S_3 is ON and S_2 & S_5 are switched simultaneously at the switching frequency. The current will flow through $S_5 - S_3$ returning through S_2 . During the negative zero voltage, again switches S_4 and S_5 are turned OFF and hence the freewheeling current flows through S_3 and diode of S_1 .

The different operating modes of H5 topology is shown in Fig. 6.

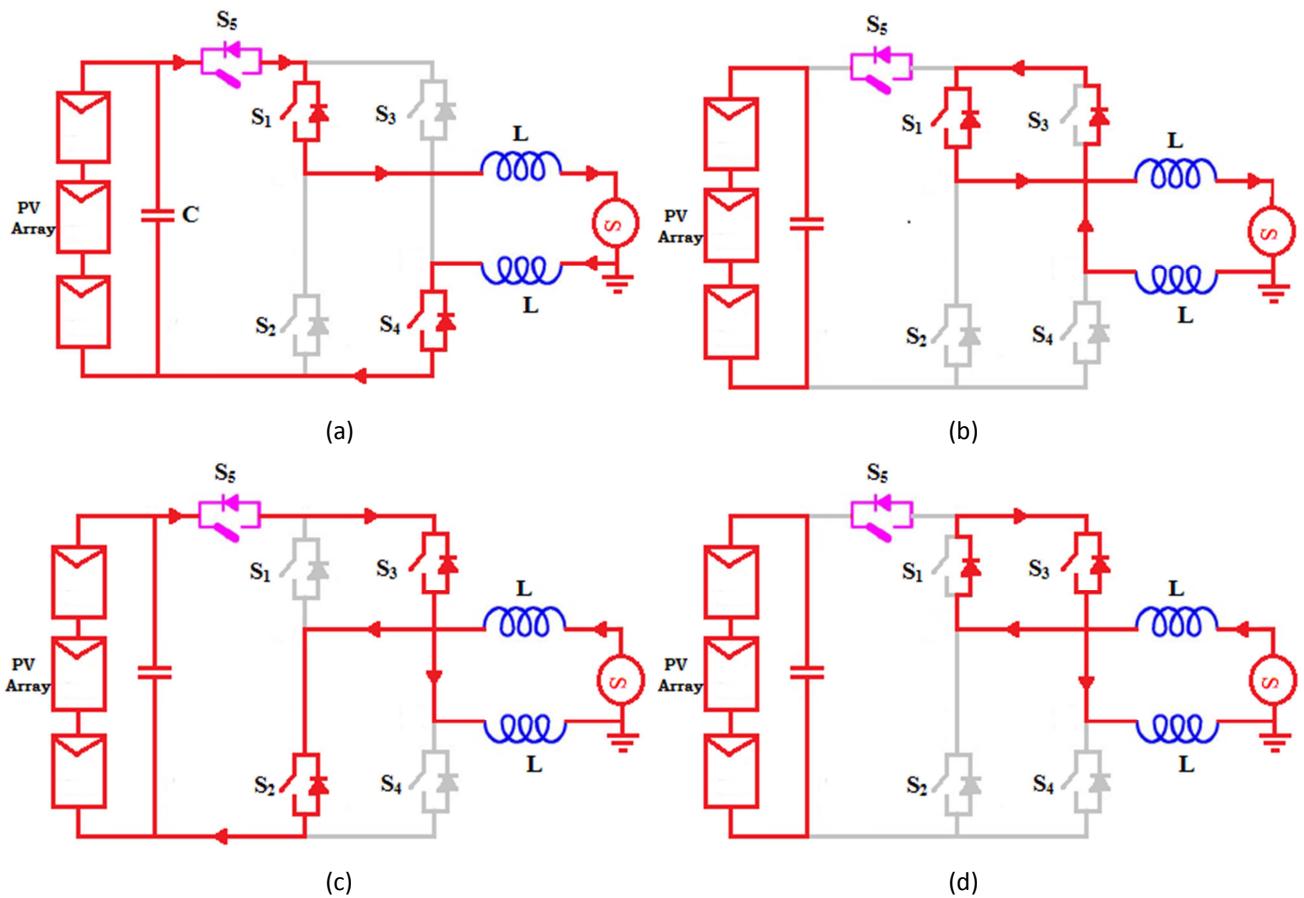

Fig. 6. Different modes of operation (a) Active mode during the positive half cycle. (b) Freewheeling mode during the positive half cycle. (c) Active mode during the negative half cycle. (d) Freewheeling mode during the negative half cycle.

5 SIMULATION RESULTS

This section discuss the various observations obtained from the simulation results of photovoltaic array with H5 inverter. Using the mathematical equations of the solar cell, the single diode model of solar cell is developed in the MATLAB software. The simulation results obtained for the PV array with H5 inverter for different shading patterns are discussed below: The switching waveforms for H5 inverter is shown in Fig. 7.

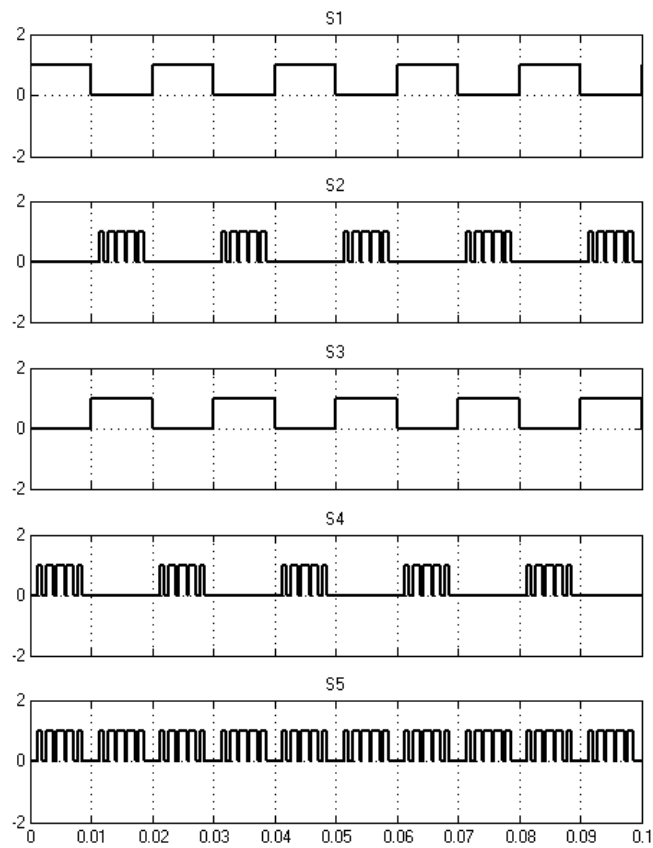
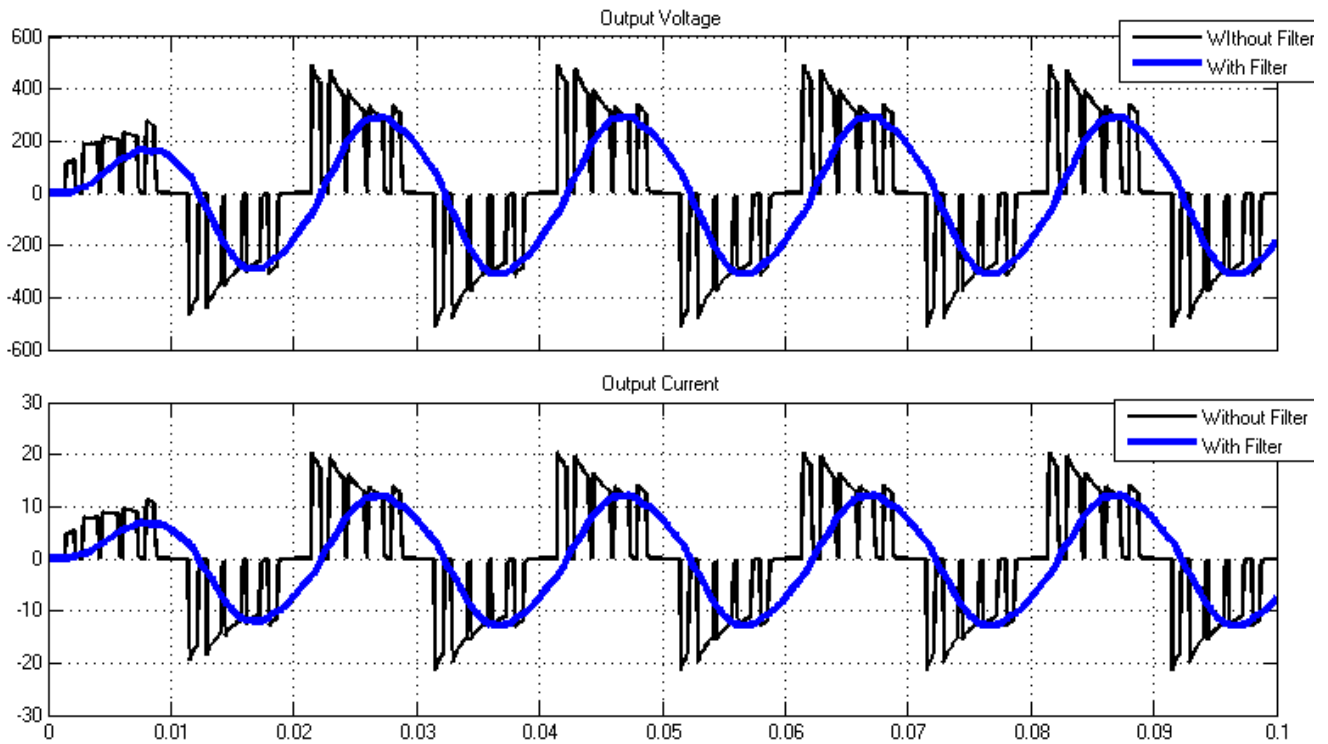
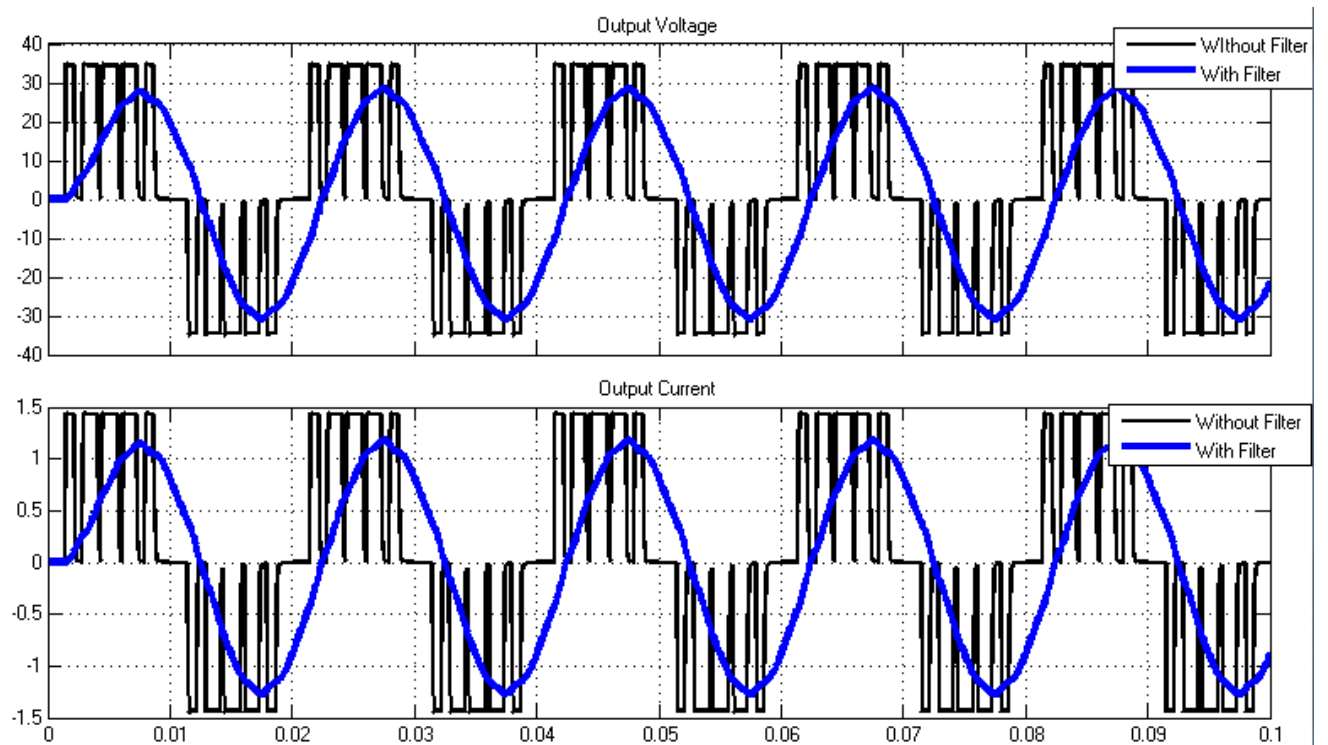

Fig. 7. Switching waveforms of H5 Inverter

The output voltage and output current waveforms obtained for different configuration of the PV array for shading pattern -1 is shown in Fig. 8.



(a)



(b)

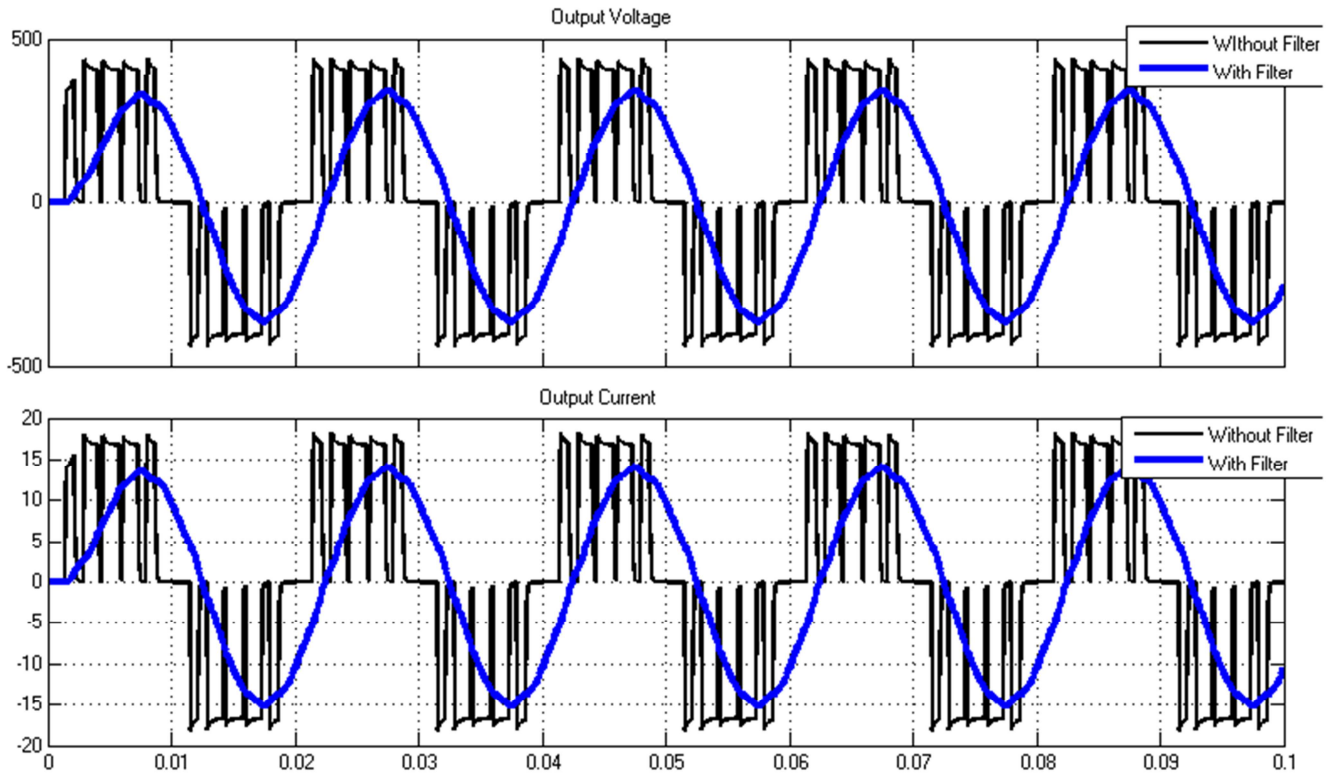

(c)

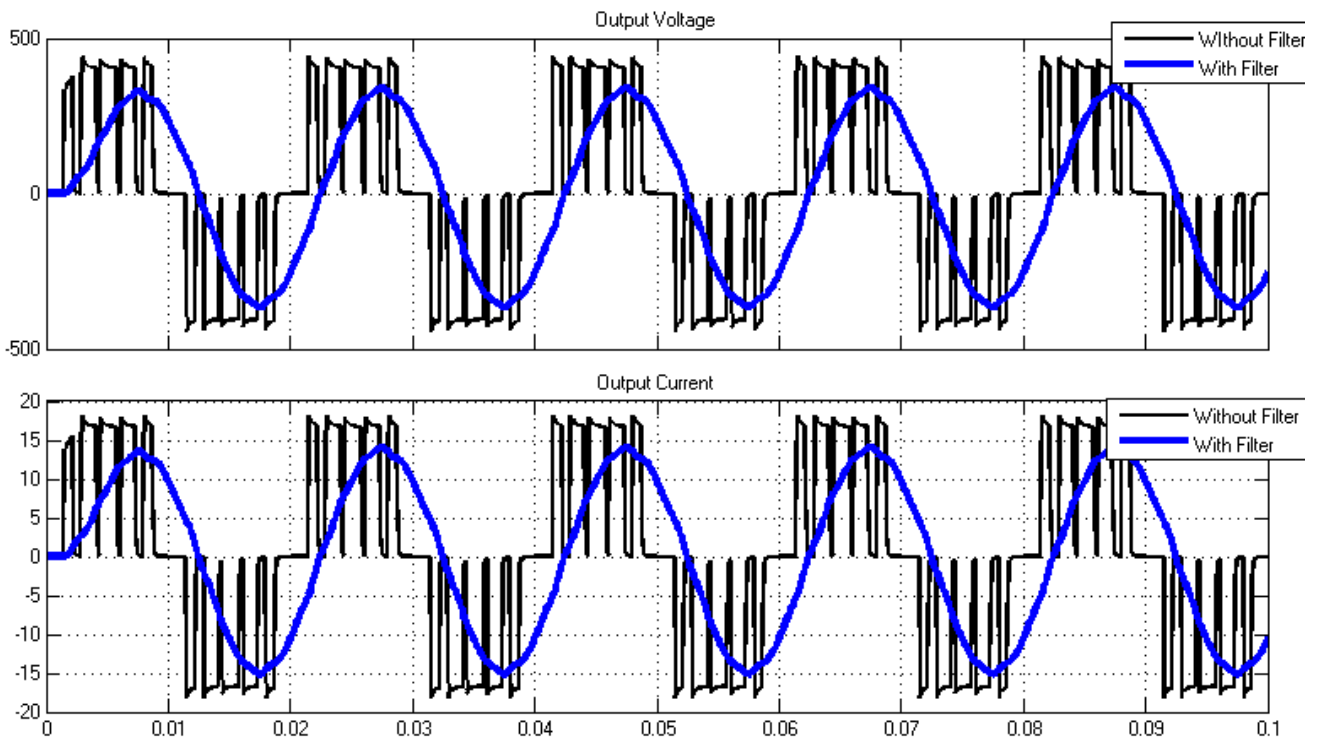

(d)

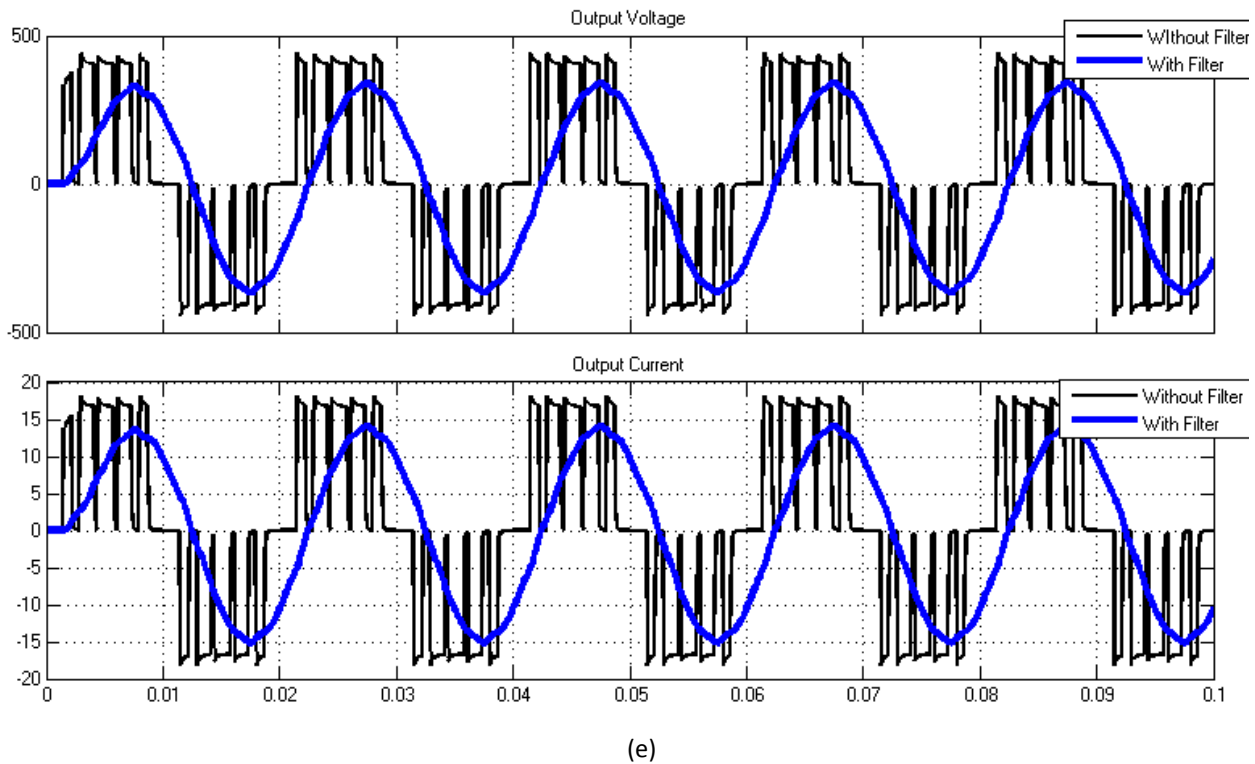
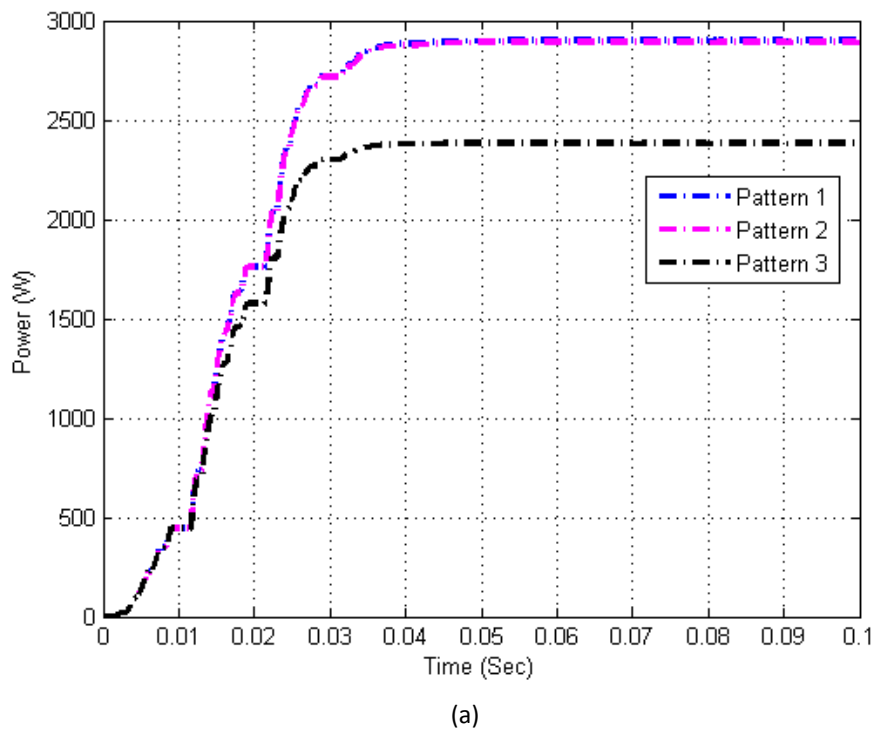
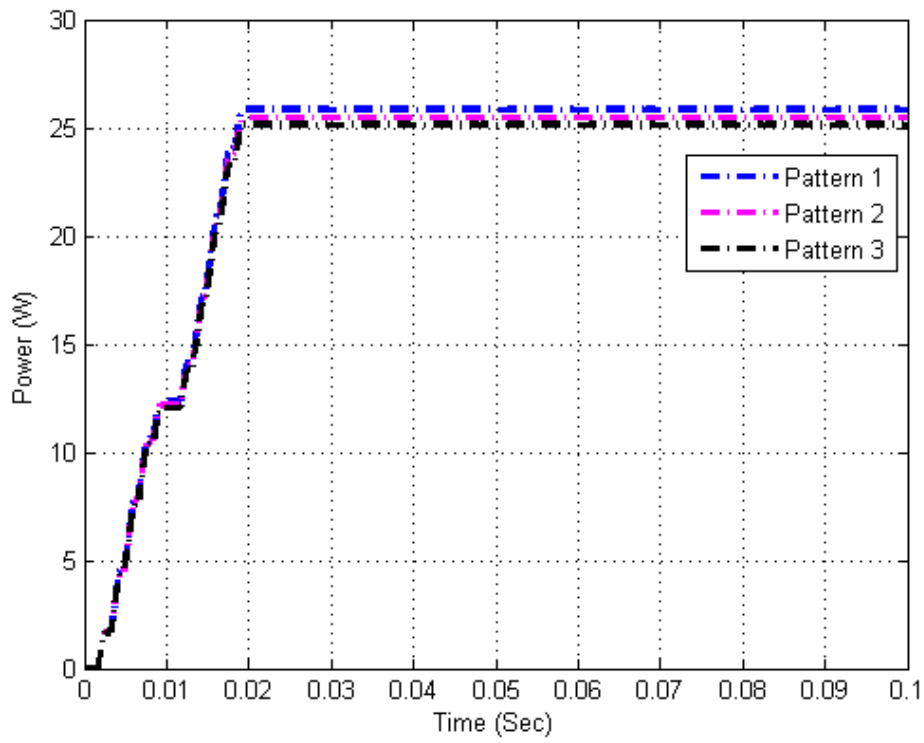

Fig. 8. Output Voltage and Output Current Waveforms (a) Series (b) Parallel (c) Series-Parallel (SP) (d) Total Cross Tied (TCT) and (e) Bridge link (BL)

The above results shows that the series-parallel, total cross tied and bridge configurations of the PV array shows better performance when compared with that of series configuration and parallel configuration of PV array. The power output of the different configurations of the PV array for different shading patterns are shown in Fig. 9.





(b)

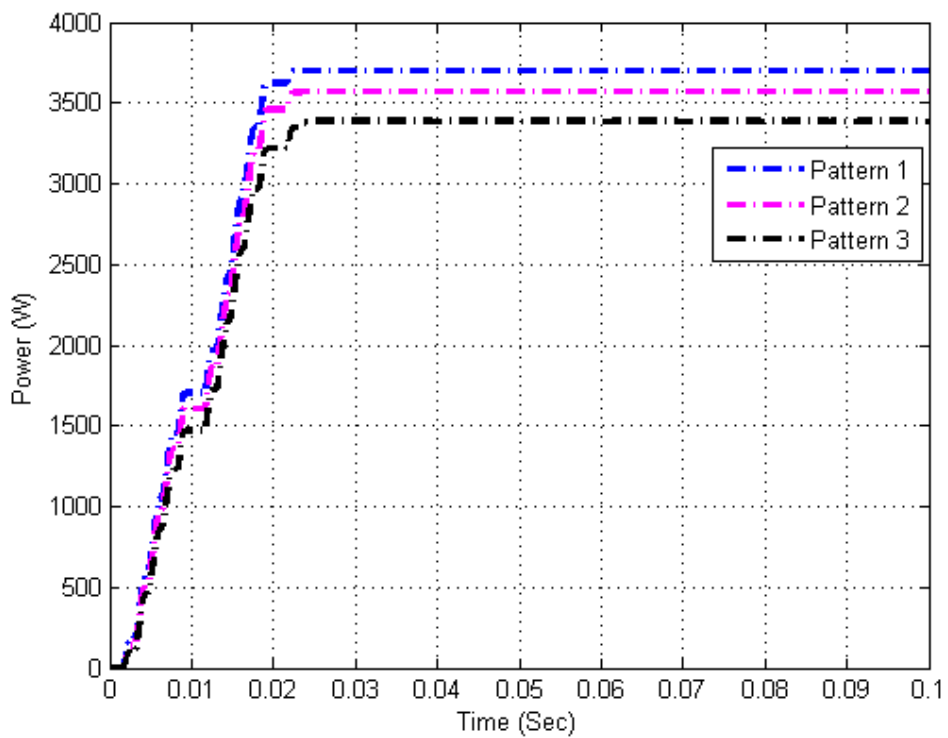

(c)

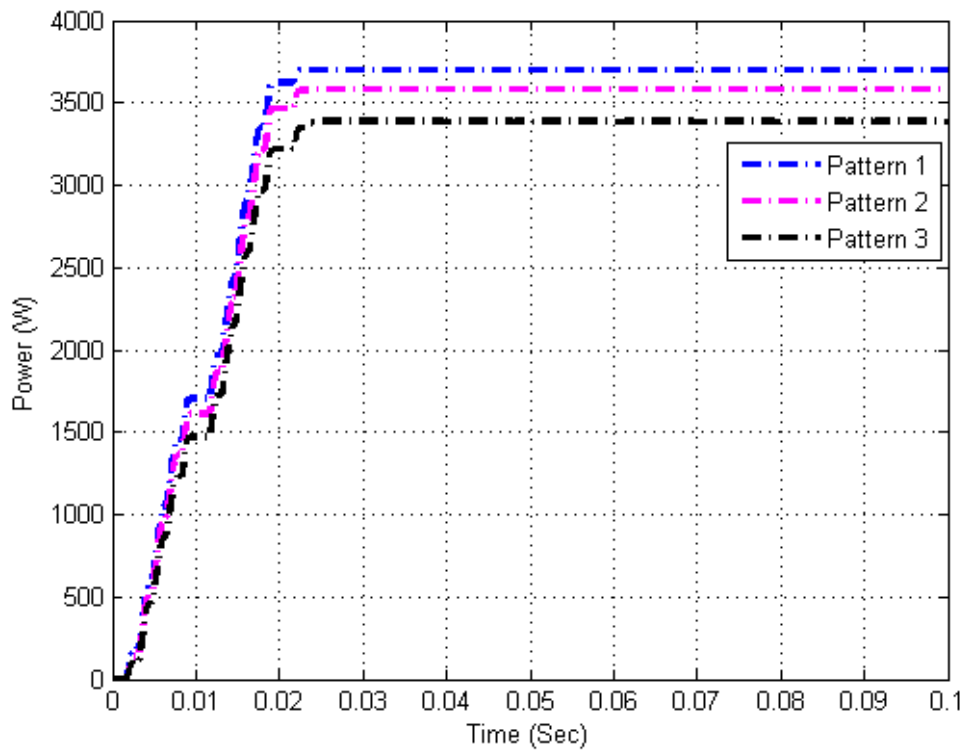

(d)

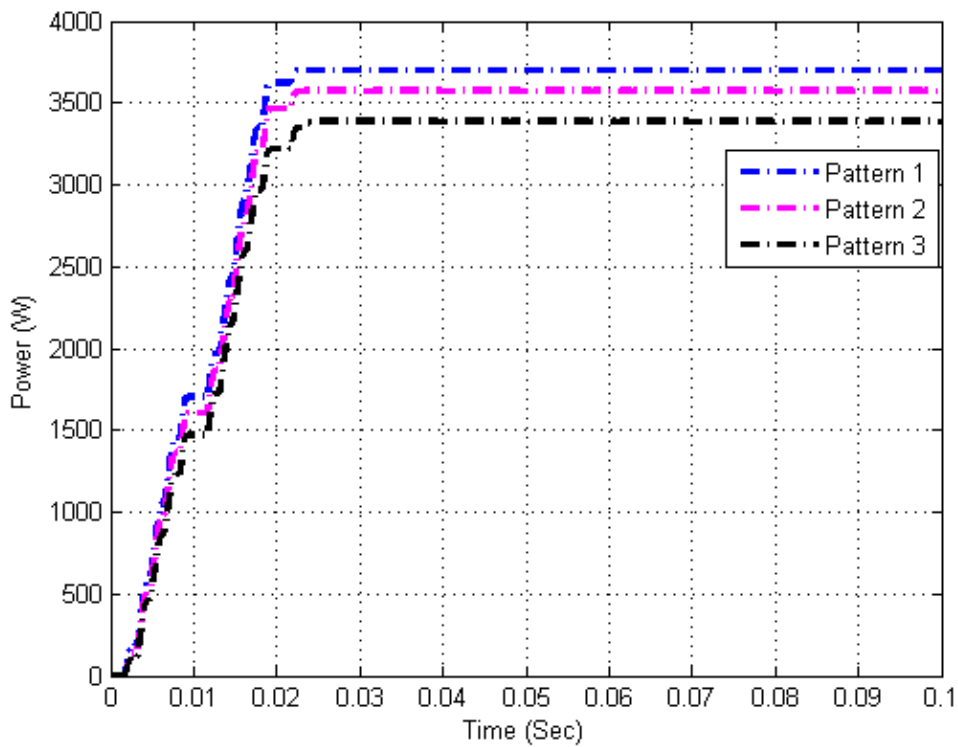

(e)

Fig. 9. Power output of PV array (a) Series (b) Parallel (c) Series-Parallel (SP) (d) Total Cross Tied (TCT) and (e) Bridge link (BL)

The efficiency of the H5 inverter for different configurations of PV array under different shading pattern is shown in Fig. 10. of the boost converter is shown in Fig. 7.

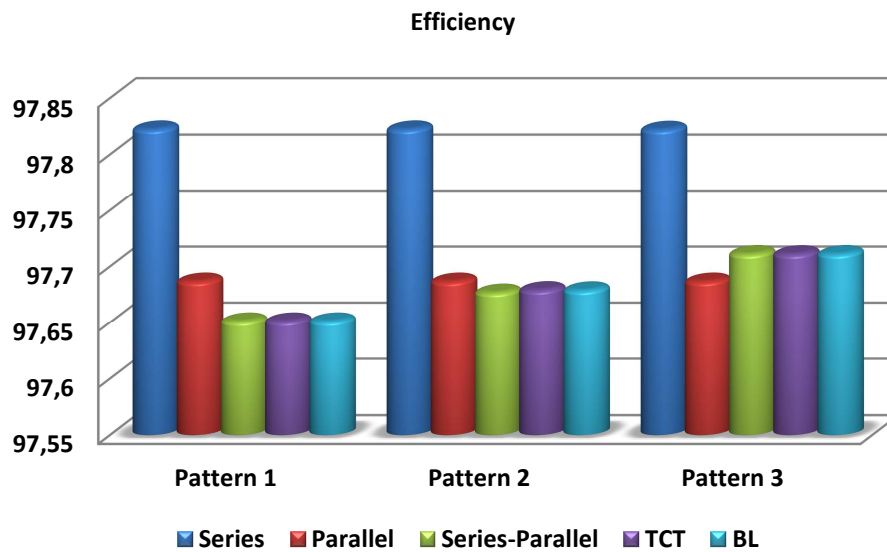

Fig. 10. Efficiency of H5 Inverter

6 CONCLUSION

The performance of different configurations of PV array under partial shading conditions is analysed. Simulation results have been given to compare the performance of the different configurations of PV array. The results shows that partial shading have greater impact on series configuration and parallel configuration of the PV array. The equal performance is achieved for series-parallel, TCT and BL configurations under partial shaded conditions of PV array. The efficiency H5 inverter for series configuration of PV array is high for all shading patterns. However, the lesser output power is obtained with that of series-parallel, TCT and BL configurations. The parallel configuration of PV array shows poor performance for all shading patterns and hence it is not suitable for PV applications.

REFERENCES

- [1] V. G. Gerardo, M. R. P. Raymundo and S. Z. J. Miguel, "High Efficiency Single-Phase Transformer-less Inverter for Photovoltaic Applications", *Ingeniería Investigación y Tecnología*, Vol.16, no. 22, pp.173-184, 2015.
- [2] R. Gonzalez, E. Gubia, J. Lopez, and L. Marroyo, "Transformerless single-phase multilevel-based photovoltaic inverter," *IEEE Transactions on Industrial Electronics*, vol. 55, no. 7, pp. 2694–2702, 2008.
- [3] V. Thiyagarajan, and P. Somasundaram, "Optimization Of Grid-Connected Solar Array Using P & O Based MPPT Algorithm With Current Reference Converter," *International Journal of Applied Engineering Research*, vol. 10, no. 4, pp. 3782–3786, 2015.
- [4] Tara-Salmi, MounirBouzguenda, Adel Gastli, Ahmed Masmoudi, "MATLAB/Simulink Based Modelling of Solar Photovoltaic Cell", *International Journal of Renewable Energy Research*, Vol.2, pp.213-218,2012.
- [5] G. N. Tiwari, Swapnil Dubey, *Fundamentals of Photovoltaic Modules and Their Applications*, RSC, 2010.
- [6] Wuhua Li, Yunjie Gu, Haoze Luo, Wenfeng Cui, Xiangning He, and Changliang Xia, "Topology Review and Derivation Methodology of Single-Phase Transformerless Photovoltaic," *IEEE Transactions on Industrial Electronics*, vol. 62, no. 7, pp. 4537–4551, 2015.
- [7] Samuel Vasconcelos Araújo, Peter Zacharias, and Regine Mallwitz, "Highly Efficient Single-Phase Transformerless Inverters for Grid-Connected Photovoltaic Systems," *IEEE Transactions on Industrial Electronics*, vol. 57, no. 9, pp. 3118–3128, 2010.
- [8] D. G. Holmes and T. L. Lip, *Pulse Width Modulation for Power Converters*, 1st Ed. Wiley, 2003.
- [9] S. B. Kjaer, J. K. Pedersen, and F. Blaabjerg, "A review of single-phase grid-connected inverters for photovoltaic modules," *IEEE Transactions on Industrial Electronics*, vol. 41, no. 5, pp. 1292–1306, 2005.
- [10] J. Ventre and R. Messenger, *Photovoltaic Systems Engineering*, CRC Press, New York, 2000.