

## Automated Wireless Fingerprint Attendance System

*Mr Sagar Wale<sup>1</sup> and Prof. Dr. S.A. Patil<sup>2</sup>*

<sup>1</sup>HOD in E&TC dept. of DMPR's Institute, Karad, Maharashtra, India

<sup>2</sup>Professor in E&TC dept. of DKTE'S, Textile & Engineering Institute, Icalkarngi, Maharashtra, India

Copyright © 2014 ISSR Journals. This is an open access article distributed under the *Creative Commons Attribution License*, which permits unrestricted use, distribution, and reproduction in any medium, provided the original work is properly cited.

**ABSTRACT:** Apart from traditional wired attendance systems or paper based attendance system a automated wireless fingerprint attendance system based on ZigBee technology is proposed. The system includes independent fingerprint acquisition module and attendance management module in computer. System realizes various functions such as information acquisition of fingerprint, processing, wireless transmission, fingerprint matching, and attendance management. Automatically considering topology of ZigBee network, the system uses wireless local area network. System comprises various wireless fingerprint attendance functions, which could be used for public/private institutes or schools.

**KEYWORDS:** ARM7 LPC2138, Fingerprint, Keyboard, Microcontroller, Time attendance, Visual basic 6 software, Zigbee network.

### 1 INTRODUCTION

Time attendance policy is a very important part of enterprises and public institutions, industry, etc. Card clocking and other traditional clocking ways once enhance working efficiency, leads to immeasurable economic loss. Fingerprint time attendance is developed according to fingerprint's uniqueness and invariance, one person, one fingerprint. So avoid fake attendance, and attendance management people do not feel awkward, so company, friend and employee are all happy finally. The Fingerprint time attendance consist of fingerprint capture and transfer, fingerprint image processing and wireless transfer of data in a server-client system.

Biometrics fingerprint recognition is universally applied. The student attendance system is very relevant in an institute like ours since it aims at eliminating all the hassles of roll calling and malpractice and promises a full-proof as well as reliable technique of keeping records of student's attendance. Once student attendance is scan by finger print scanner, it is recognized. ZigBee network, the system uses wireless local area network for transferring finger image via ARM7 LPC2138 [1], [2], [3] microcontroller and LCD. LCD is used for viewing fingerprint success or fail. All students make use of Fingerprint time attendance. Finally daily and monthly student attendance is created by using Microsoft excel sheet. Defaulter student parent's gets SMS from college uses ZigBee network. Keyword Fingerprint time attendance, ZigBee network, ASCII value of that key is provided to the microcontroller via software.

### 2 SYSTEMS IMPLEMENTATION

System is fully automatic gives various outputs like database is created, Daily attendance monthly attendance created and SMS is sent to parent mobile no.

## 2.1 BLOCK DIAGRAM DESCRIPTION

### KEYPAD

Keypad is basically used to provide the input to the microcontroller. The keypad consists of micro switches which are connected to the microcontroller pins in a matrix format. Each key is assigned with the special character or symbol or digit. When user presses the key the respective assigned.

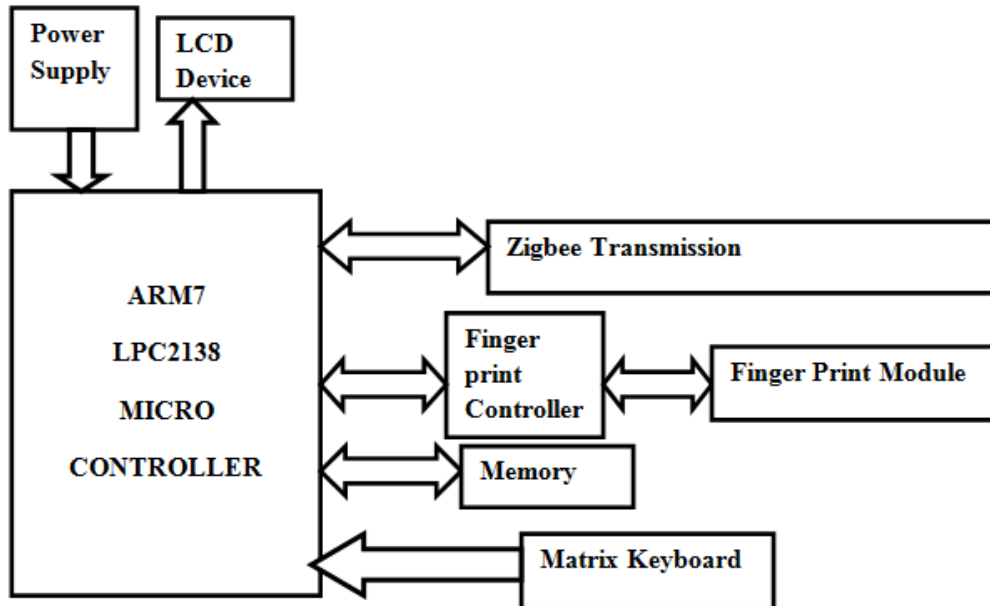

Figure 2.1 Block diagram of fingerprint wireless monitoring system

### 2.2 LIQUID CRYSTAL DISPLAY

LCD is used in a project to visualize the output of the application. We have used 16x2 LCD which indicates 16 columns and 2 rows [4], [5]. So, we can write 16 characters in each line. So, total 32 characters we can display on 16x2 LCD. LCD can also be used in a project to check the output of different modules interfaced with the microcontroller. Thus LCD plays a vital role in a project to see the output and to debug the system module wise in case of system failure in order to rectify the problem.

### 2.3 MEMORY

The FM24C256/C256L/C256LZ devices are 256 Kbits CMOS nonvolatile electrically erasable memory. These devices offer the designer different low voltage and low power options. They conform to all requirements in the Extended I<sup>2</sup>C 2-wire protocol. Furthermore, they are designed to minimize device pin count and simplify PC board layout requirements. The entire memory array can be write disabled (Write Protection) by connecting [2] the WP pin to VCC. Functional address lines allow up to eight devices on the same bus, for up to a total of 2 bit address space. The I<sup>2</sup>C communication protocol uses CLOCK (SCL) and DATA I/O (SDA) lines to synchronously clock data between the master (for example a microprocessor) and the slave EEPROM device(s). Fairchild EEPROMs are designed and tested for applications requiring high endurance, high reliability, and low power consumption. Extended Operating Voltages C256: 4.5V - 5.5V C256L: 2.7V - 5.5V, C256LZ: 2.7V - 5.5V, Low Power CMOS, 1mA active current typical, C256/C256L: 10µA standby current typical, C256LZ: less than 1µA standby current, 2-wire IIC serial interface, 64 byte page write mode, Max write cycle time of 6ms byte/page, 40 years data retention, Endurance: 100,000 data changes, Hardware write protect for entire array, Schmitt trigger inputs for noise suppression, Electrostatic discharge protection. 8-pin DIP and 8-pin SO (150 mil) packages. Contact factory for CSP package availability the various features that we are going to develop along with various Technologies that we will learn to develop the Project are here I use VB6 based software control, for serial communication between Finger Print Module & PC, PCB Making & Assembling. 230 V Power Supply Designing, Serial Communication Protocol. Interfacing LCD with Microcontroller.

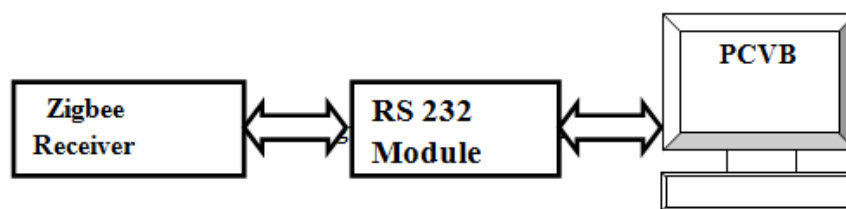

*Figure 2.2 Unit on table in HOD's cabin*

Here as we can see from the block diagram figure 2.1 & figure 2.2 there are 2 different units:

1. Unit in the class room
2. Unit on table in HOD's cabin

#### 2.4 UNIT IN THE CLASS ROOM

Following are the different section of above mentioned hand held unit Here the classroom unit is placed in the classroom [1], [8]. The teacher will enter the teacher ID first then the subject ID. Then microcontroller will display the teacher name and the subject name on LCD. After this the students have to press the finger on fingerprint unit.

#### 2.5 FINGER PRINT READER UNIT

This unit is interfaced to the microcontroller and is situated in the classroom of the school or college. As soon as the student presses the finger the reader will recognize the fingerprint and store the attendance record on serial memory .All the attendance records will be stored in the memory. At the end of lecture the microcontroller will send the attendance records to PC via ZIGBEEEE based RF module. For wireless transmission we are using Zigbee module which works at 2.4 GHz and a range of 30 meters. The fingerprint can recognize up to 200 fingerprint ID's. All these ID's are stored in the fingerprint module. This unit or setup is placed in classroom or worker room. Consist of various components like power supply used for supplying the power 5 volt to supporting IC and 3.3 volt to [1],[6],[7] ARM LPC2138 Microcontroller, LCD device for display the student information to read the figure print information like pass or fail, Zigbee transmission is used for transmitting micro controller information to unit placed in Manager's or HOD's cabin also Zigbee work as trans receiver means it can work as receiver it also receives information from unit placed in Manager's or HOD's cabin, finger print controller and finger print module. Finger print module is the sensor which senses the student finger and gives output to finger print controller and finger print controller converts this output in digital form and gives output to ARM7 LPC2138 microcontroller. Memory & Key board.

#### 2.6 PC UNIT

The PC received the Fingerprint information wirelessly from classroom unit from the student compares it with the database of the students stored in the PC. It then sends an SMS to the concerned parents that the particular student has entered the school premises with in time of entry. Similarly this unit will send a SMS as soon as the student exits the school .In this way the parents get intimation during in time and out time of the respective student. Thus every parent will get an SMS that the student has reached the school in time. In case any parent doesn't get the SMS in time they can enquirer about student [9], [10]. The SMS is sent using the dedicated mobile connected to the school PC using AT commands. In this unit various components are connected. This Unit placed in HOD / Manager's cabin. Graphic user interface (GUI) has been prepared using Visual Basic 6 keil 'C' compiler is used to compile embedded 'C' programming Other components like RS 232 Module which is used for converting 9 volt from PC to 5 volt which is the voltage of Zigbee is receiver. So this voltage conversion is carried out by RS 232. Zigbee receiver which receives student information is transreceived in between finger print reader and PC via zigbee modules and microcontroller.

### 3 ABOUT GUI

Visual basic software version 6 is used in my project. Here Visual Basic software is taken as front end and excel sheet taken as back end. Other details use of visual basic is shown in figure 4.1 and 4.2.

Figure 4.1 Visual basic attendance function windows on pc in cabin

Figure 4.1 shows visual basic attendance function windows on pc in HOD cabin. In this figure we can upload student information, make defaulter of student, make student mark list, add new student and clear or delete student information [11], [12]. All these functions are making possible with the visual basic software in PC.

Figure 4.2 Visual basic attendance function windows in class room

Here upload button is used for filling the student information in the flux grid. Student information is filling the student name, his/her ID, in date and in time. Add new button is used for filling or updating new student information like student name and his/her ID is shown in figure 4.2. Daily attendance button is used for taking student attendance for particular date and stored in excel sheet; Monthly attendance button is used for same. Clear button is used for removing the student information in the flux grid. Clear memory card used for removing the stored student information. Faculty or Staff must fill information about semester is going on, which classroom is used for conducting lecture, Subject name, Lecture number and a faculty name.

Figure 4.1 and figure 4.2 shows visual basic attendance function windows in class room. In this figure 4.2 we can add details, adding student ID, adding student name etc.

## FLOWCHART

Flowchart explains how electronics attendance system as shown in figure 4.3.

Initial assign all different variables like UART1, UART 0, Timer1, Intervertor ADC1, RTC month, day, hour, minute, second using Case statement Write into EEPROM using following command, I<sup>2</sup>C serial bus and flash pass. And flash fail. I<sup>2</sup>C is used to . Transmit this string via UART1 though ZIGBEE device to LCD. Check for Master Mode Character 7E in the data buffer and 4 locations in flag register is 1 and 8 location in flag register is 1 then and then master mode is successful. For all other location

in flag register master mode is fail. As master mode is successful User is registered Set proper password, set ID, enter ID. Check for Key pressed, if no then cancel out. If yes enter password, verify password, Identify ID, Verify ID.

Student information receiving flowchart is shown in figure 4.4. This flowchart giving details like how to work with software. We use visual basic version 6 it works on windows XP or other windows platform. Initial open V.B. software click attendance file then select Hardware = 1 to 16 and Mobile = 1 to 16 V.B. not support after 16 signals. Click ok then form 1 open if click on add new button then form 3 opened. This add new button used for filling or updating new student information like student name and his/her ID is shown in figure 4.2 After filling student information if you click on exit button then form 2 will open, So form 2 is main form where click on upload button & edit MS comm. output = #D & data will be saved otherwise check Binging of file & end of file click on clear button = #Z & data will be erased. Take Counter = 0. Field set bit 1 = true then data saved if set bit 1 = false data deleted. Click on daily attendance button upon filling information output excel sheet is created & we get detailed report of students as shown in figure 4.4 In form 2 click on monthly attendance button Upon filling all the information output excel sheet is created & we get required data as shown in figure 4.5 For defaulter students Lect. No. = # Lect. Conducted = # % attendance = lect. conducted / lect. no. \* 100. If % attendance < 75 then send SMS to the parents mobile no. Attendance displayed on LCD by using Zigbee trans receiver same information to ARM7 LPC2138

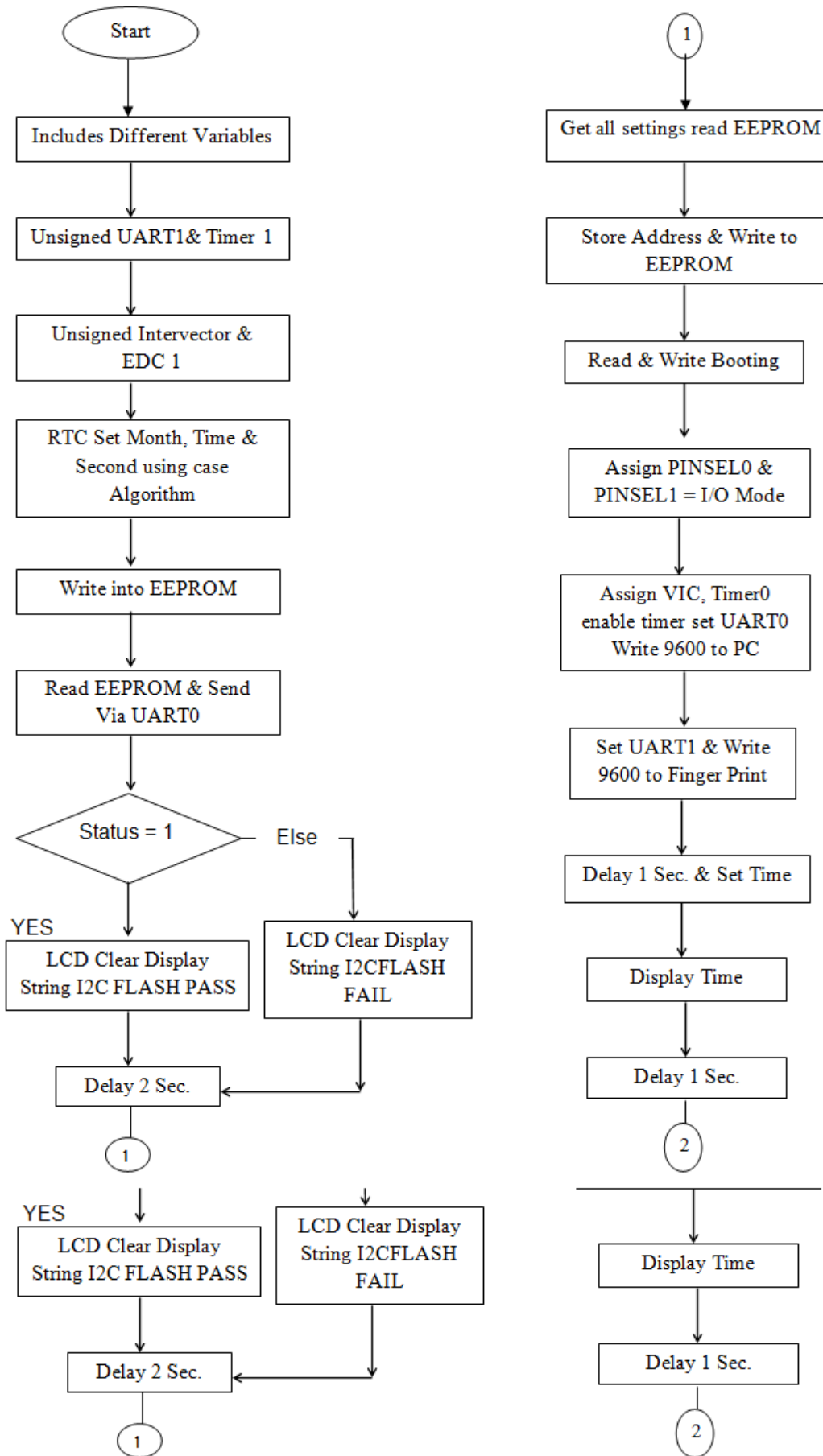

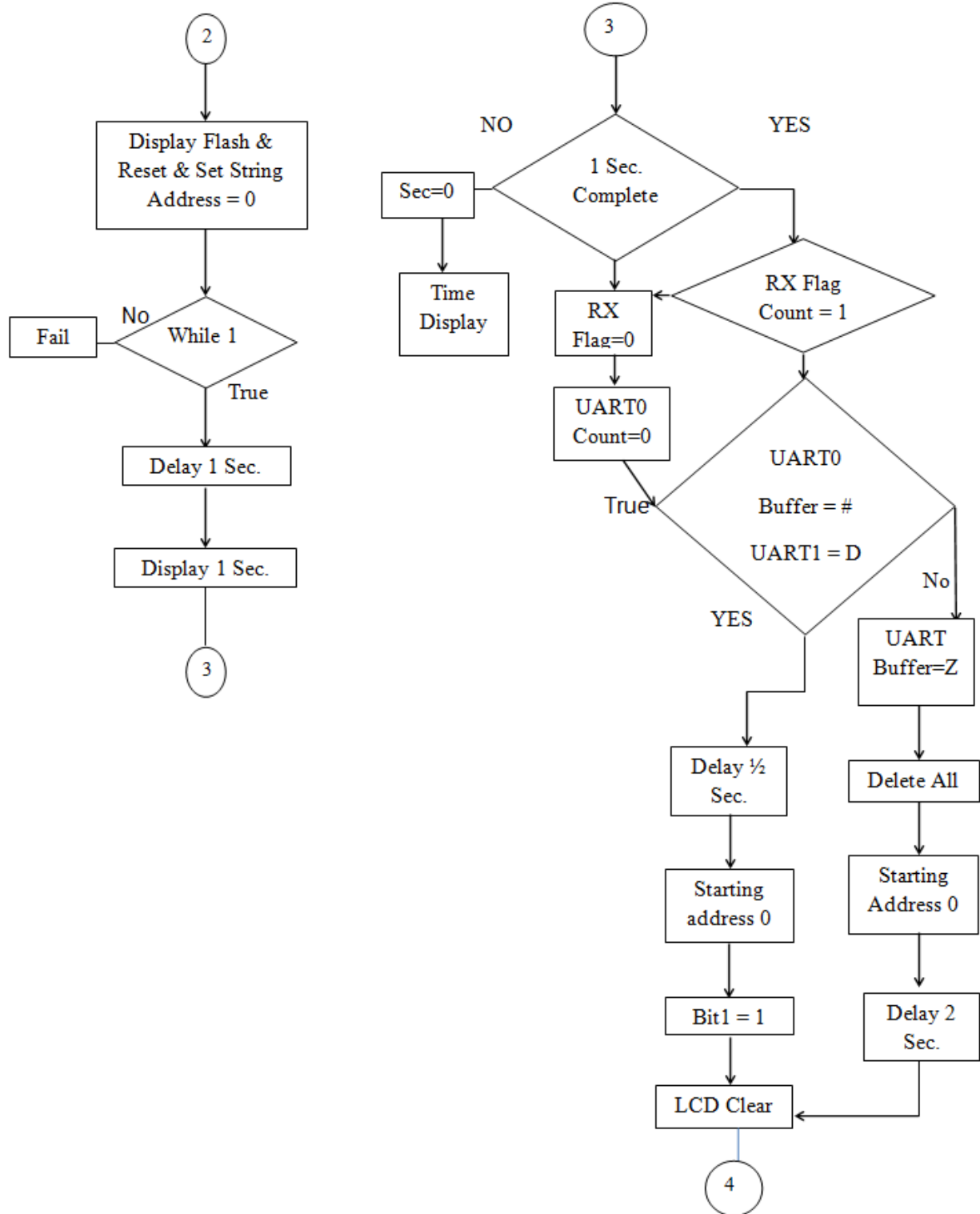

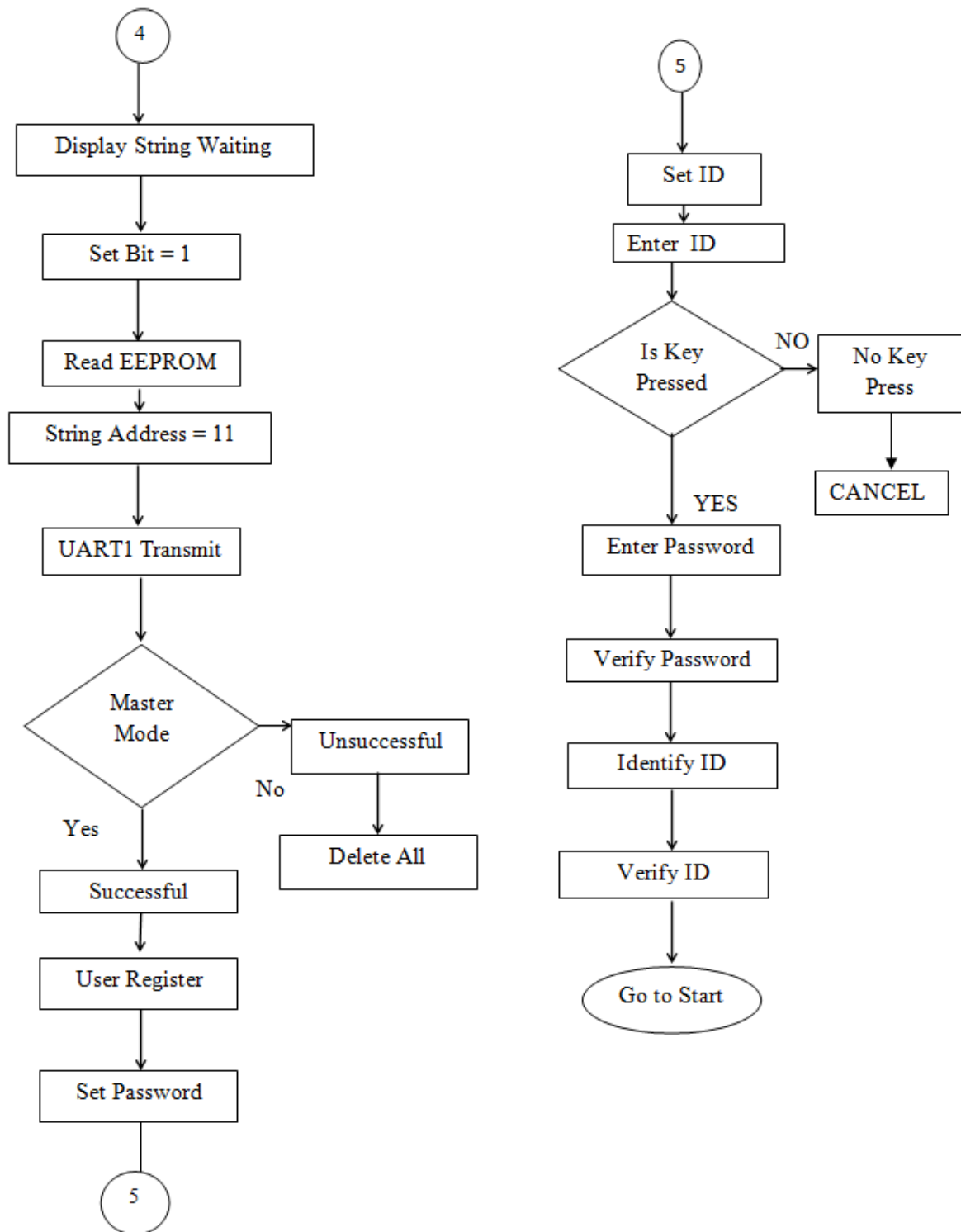
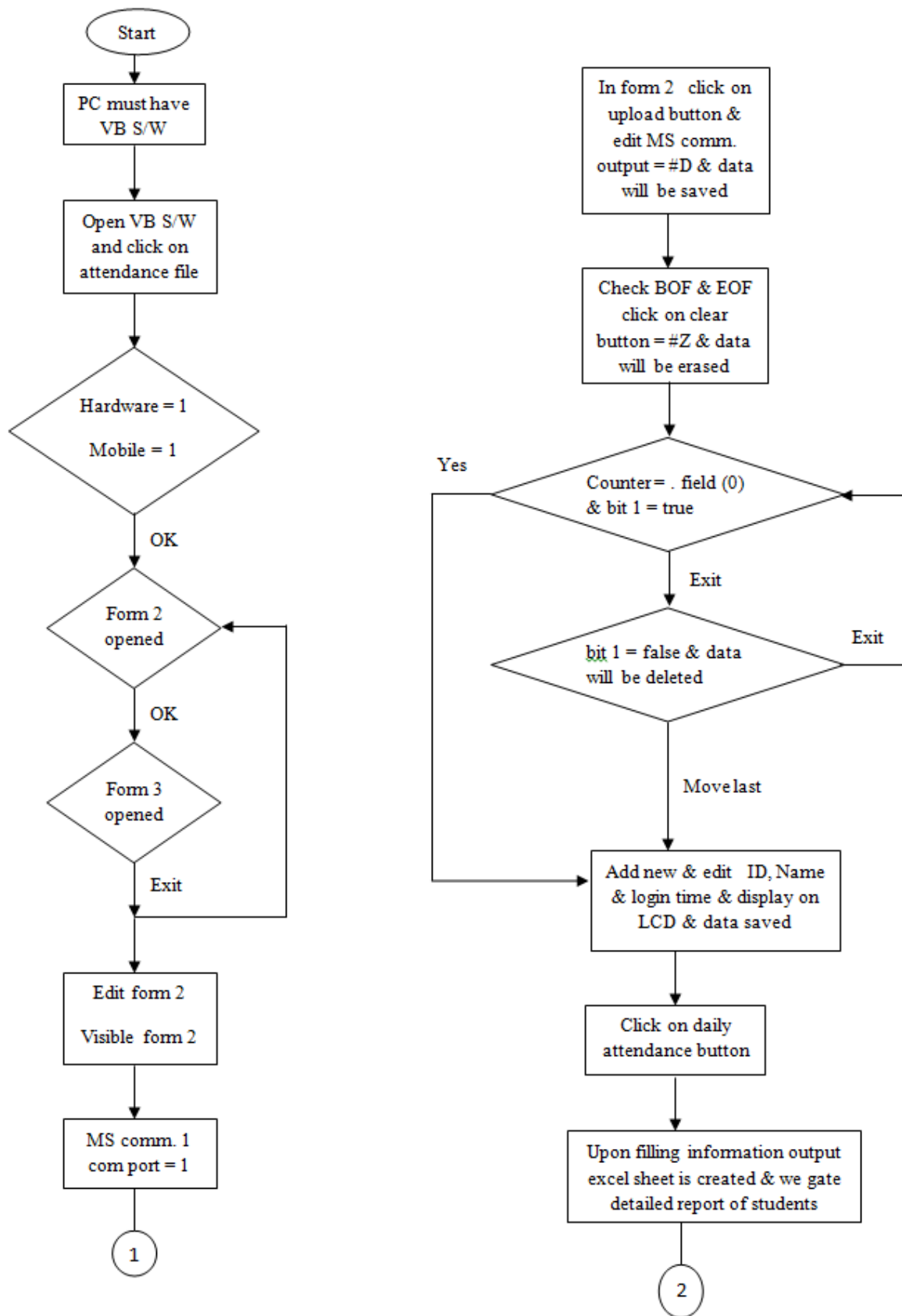

Figure 4.3 Flowchart for electronics attendance system functionality





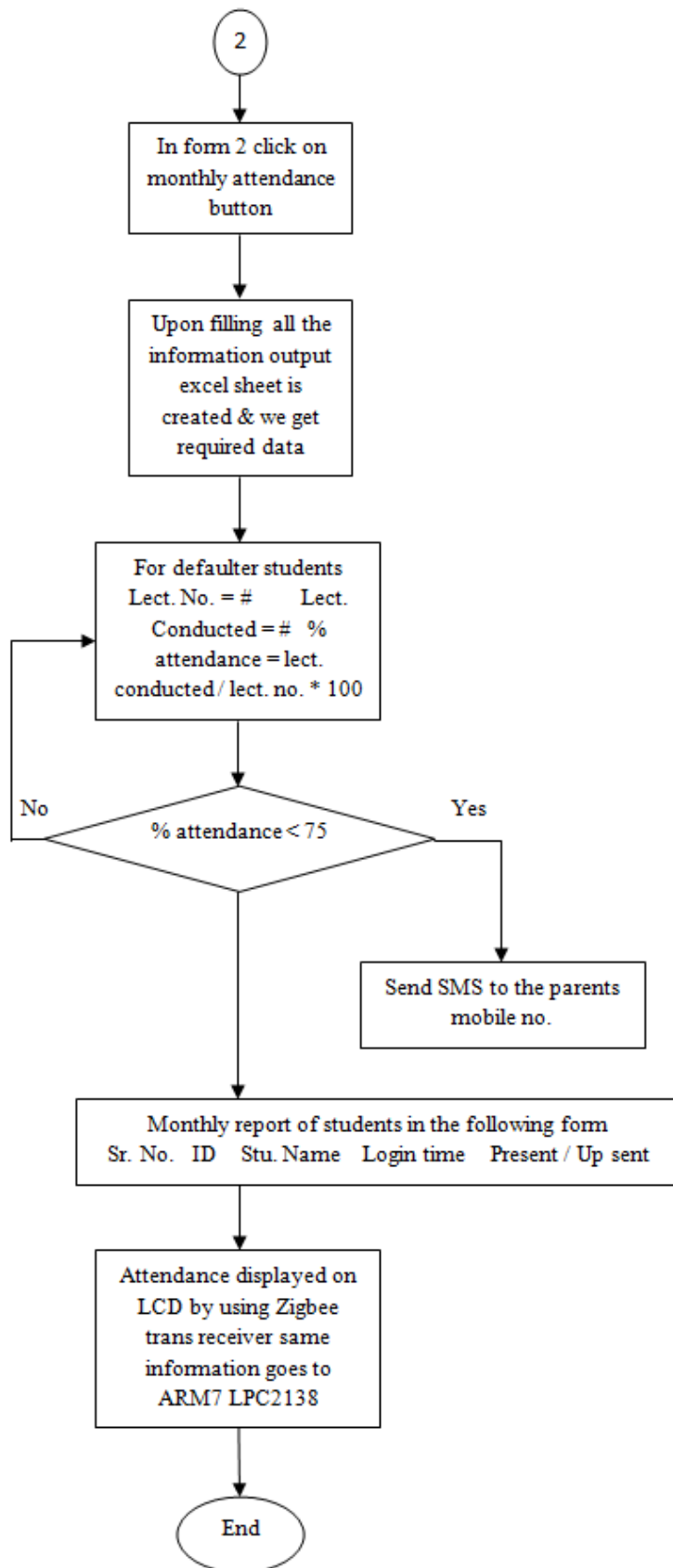

Figure 4.4 Student information receiving flowchart

#### 4 RESULT

The result of electronics attendance system is shown below. Daily attendance is shown in fig 4.4 which is excel sheet in details. The Daily attendance includes column name like this sr.no, student name, ID No, Lecture No, Student in time, and present/absent. Below these columns we get details of every student

Monthly attendance is taken after 30 days excel sheet is show in the fig 4.5 Monthly attendance includes column name like ID, student name, Lecture attended, % attendance. Below 75% attendance or absent student will get SMS to parent mobile number

*Table 4.4 Daily attendance details report*

ATTANDDANCE DETAILS					
	DATE 7.4.14		Time 12.00 am		
	Lectures Name Wale S.G.				
	Class B	SEM IV	Subject Name MCN		
Sr.No	Student Name	ID.No	Lecture no	InTime	Present/Absent
1	Kakade Pritee	3431	1	11.55	Present
2	Jadhav Prasad	3432	1	11.55	Present
3	Jadhav Pankaj	3433	1	11.55	Present
4	charankar shobharaj	3442	1	11.55	Present
5	Dange Suraj	3439	1	11.55	Present
6	chavan shubhabgi	3440	1	11.55	Present
7	chavan Madhuri	3441	1	11.51	Present
8	Shikargar Himayatuddin	3409	1	11.51	Present
9	Bhosle Rohit	3443	1	11.51	Present
10	bandal Madhuri	3444	1	11.51	Present
11	Angarkhe Netradip	3446	1	11.51	Present
12	Pawar Saraswati	3418	1	11.51	Present
13	Patil sagar	3419	1	12.01	Present
14	Mane suhant	3425	1	12.01	Present
15	Khochare Nikhil	3426	1	12.01	Present
16	Khmbhar Vikas	3427	1	12.01	Present
17	Karape Sambhaji	3428	1	12.01	Present
18	Kalkure Bhagyeashti	3429	1	12.01	Present
19	Gadave Kiritika	3435	1	11.55	Present
20	Desai Pradhnya	3436	1	11.49	Present

Table 4.5 Monthly attendance details report

Attendance List for month : May 2014			
Date:	30-05-2014	Time	11.02 am
Class:	3rd		
Subject:	MCN		
Lecturer Name	Mr. Wale S.G.		
Lectures Allotted	15	Lectures Delivered	10
ID	Student Name	Lecture Attended	Attendance (%)
3414	Raut Neha	5	50
3415	Raut Aniket	5	50
3416	rane ankit balu	5	50
3417	Pawar Yogesh	5	50
3418	Pawar Saraswati	5	50
3419	Patil sagar	5	50
3420	Patil Pradnya s	10	100
3421	Patel Afsana	10	100
3422	omkar mhetar	10	100
3423	nilima sale	10	100
3424	Nangare Arti	10	100
3425	Mane suhant	5	50
3426	Khochare Nikhil	5	50
3427	Khmbhar Vikas	5	50
3428	Karape Sambhaji	5	50
3429	Kalkure Bhagyashti	5	50
3431	Kakade Pritee	5	50
3432	Jadhav Prasad	5	50
3433	Jadhav Pankaj	5	50
3434	Ghadage sweta	2	20.45
3435	Gadave Kiritika	3	27.89
3436	Desai Pradhnya	3	27.89
3437	Deokar Anil	3	27.89
3438	Deepak Baburao Pakhare	3	27.89
3439	Dange Suraj	3	27.89
3440	chavan shubhabgi	3	27.89
3441	chavan Madhuri	3	27.89
3442	charankar shobharaj	3	27.89
3443	Bhosle Rohit	0	0
3444	bandal Madhuri	0	0
3446	Angarkhe Netradip	2	20.45

## SOFTWARE

LPC2138 microcontroller is used for programming at base station using visual basic (6.0). It gives advantages like efficient way for attendance monitoring, less time delays, quick response time fully automate system,[9],[10] robust system, low power. Applications attendance monitoring system can be used for offices, institutions etc can be used for wireless hazardous areas such as oil rigs, mines etc.

## 5 CONCLUSION

It can be concluded from the all above discussion that a se-secure, fast, reliable and an efficient system has been developed replacing a manual and unreliable system. The fingerprint sensor successfully captured new fingerprints to be stored in the database; fingerprints placed on the device sensor [13], [14] and compared them with those stored in the database

successfully. The system successfully took the attendance both at lectures and examinations. The prototype successfully captured new fingerprints to be stored in the database; scanned fingerprints placed on the device sensor and compared them against those stored in the database successfully. The performance of the system was acceptable and would be considered for full implementation especially because of its short execution time and reports generation. Everyone who tested the system was pleased and interested in the product being developed for use in schools.

#### **ACKNOWLEDGEMENT**

I express my deep sense of gratitude to my guide Prof. (Dr.) S. A. Patil [Guide, Head Electronics and Telecommunication Engineering Department] for their impeccable guidance, unflinching encouragement, keen interest, painstaking corrections and constant criticism throughout the course of study. This work would not have taken a desirable shape without their untiring efforts and great pains that they have taken in the conduct of the entire studies. Their truly scientific intuition has inspired me for my work.

I would like take this opportunity to thanks to Prof. (Dr.) P. V. Kadole, Principal of D.K.T.E.Society's Textile and Engineering Institute, Ichalkaranji for their valuable support and guidance.

I am extremely thankful all the faculty and staff members of the Department, especially Prof. Dr. (Mrs.) L.S.Admuthe, (Vice Principal, Head Electronics Engineering Department), Mrs. V. Jayshree, I would also like to thanks to my friends and colleague, without their support it was not easy to complete this dissertation work. It is hard finding words to express my gratitude to my parents for continuous encouragement and inculcating the right spirit of mind. Without their positive, kind and silent support this work neither has been possible nor could it have been completed. Last but not least, this acknowledgement would be incomplete without rendering my sincere gratitude to all those who have helped me in the completion of this dissertation work directly or indirectly.

#### **REFERENCES**

- [1] Jilin, China Zhu Xu-ning , Li Xue , Zhang Zhi-ming , Li Jian-pos, Ji-sheng Sui, "Intelligent Systems and Applications (ISA), 2010 2nd International Workshop on", *Computing & Processing (Hardware/Software)*, 22-23 May 2010.
- [2] O. Shoewu, Ph.D., and O.A. Idowu, B.Sc. "Development of Attendance Management System using Biometrics", *Journal of Computer Applications (0975 – 8887)* Vol 39, No.3, February 2010.
- [3] Talaviya, Rahul Ramteke, and A.K.Shete "An introduction to biometrics recognition, Wireless Fingerprint Based College Attendance System Using Zigbee Technology," *International Journal of Engineering and Advanced Technology (IJEAT)* ISSN: (2249 – 8958), Vol 2, Issue 3, February 2013.
- [4] Zatin Singhal Rajneesh Kumar Gujral "Design and Development of Portable RFID for Attendance System,Anytime Anywhere- Remote Monitoring of Attendance System based on RFID using GSM Network", *International Journal of Computer Applications (0975 – 8887)* Vol 39 , No.3, February 2012.
- [5] Anne Marie Dunphy, Jay Fry Ed.D, "www.identimetrics.net, Biometrics Student Identification", *Journal of Biometrics Student Identification* March 2010.
- [6] Mohd. Helmy Abd. ,Wahab, Zarina Tukiran, " www.intechopen.com, Fusion of Radio Frequency Identification (RFID) and Fingerprint in Boarding School Monitoring System", Source: *Sustainable Radio Frequency Identification Solutions*, Book edited by: Cristina Turcu, 356, and February 2010 November 13-14, 2008.
- [7] Smit M., "aceprox.de/pdf/FIM20\_Datasheet.pdf" Format: PDF/Adobe Acrobat *FIM2030/2040 Datasheet*. Description: FIM Module Series has functions of finger print enrollment, identification, partial and entire deletion and reset in a single.
- [8] Atmel, "www.datasheetarchive.com/AX-FIM2030-RE-data", United States *AX-FIM2030-RE datasheets and application notes. AX-FIM2030-RE Datasheet* Archive.
- [9] Datasheet archive "www.datasheetarchive.com/datasheet/AX-FIM20", Datasheet\_search term helper *AX-FIM2030-REUnited States*. Datasheet search term helper improve your electronic component search keywords.
- [10] DigiKey, "www.digikey.co.uk G3AX-FIM2030-RE-ND" Industrial Controls, Meters > Accessories Buy 3G3AX-FIM2030-RE Omron Electronics Inc-IA Div (3G3AX-FIM2030-RE-ND) at *digikey.co.uk. ... Datasheets, 3G3MX2 AC Drives Brochure* Standard.
- [11] Wvshare, "www.wvshare.com/datasheet\_html/LPC2138-PDF.html",*LPC2138 PDF/datasheet Download. LPC2138 Datasheet Download: LPC2138.pdf (Datasheet). LPC2138 PDF/datasheet Preview.*

- [12] XBee, “[www.sparkfun.com/datasheets/Wireless/.../XBee-Datasheet.pdf](http://www.sparkfun.com/datasheets/Wireless/.../XBee-Datasheet.pdf)” File Format: PDF/Adobe Acrobat Sep 23, 2009 – *XBee® and XBee-PRO®* are registered trademarks of Digi, Inc. Technical ... The XBee and XBee-PRO RF Modules were engineered.
- [13] Digi, “[www.digi.com/pdf/ds\\_xbeemultipointmodules.pdf](http://www.digi.com/pdf/ds_xbeemultipointmodules.pdf)” *Multipoint RF Modules - Datasheet* - Digi International File Format: PDF/Adobe Acrobat The XBee family of embedded RF modules provides OEMs with a common XBee multipoint RF modules are ideal for applications requiring low latency.
- [14] XBee, “[www.digi.com](http://www.digi.com)”, *RF Modules Bee 802.15.4* (formerly Series 1) OEM 2.4 GHz modules are ideal for low-cost, low-power